

# H6203

The Powerscreen® H range features horizontal screens ideal for handling high volumes of sticky materials and for the exact, fine sizing demanded in many construction contracts. The H6203 offers high capacity output of up to 800tph / (882 US tph).

The adjustable elliptical throw combines linear and circular amplitude producing an aggressive screening action. Powerscreen® H products are especially effective for scalping after a primary impact or jaw crusher and really have outstanding performance when screening out specific small sizes. Ideally suited to applications such as natural and crushed aggregate, coal, iron ore, recycled concrete and asphalt.

**Features & Benefits**

- High capacity variable speed belt feeder
- Oil bath screenbox bearing lubrication
- Screen walkway and access ladder
- Hydraulic folding stockpiling conveyors
- Heavy duty triple shaft screenbox with adjustable stroke, angle and speed
- Elliptical throw adjustable up to 19mm (3/4")
- Diesel hydraulic power unit
- Heavy duty, low ground pressure tracks
- Direct feed hopper with impact bars and rollers

**Options**

- Radio controlled tracking
- Roll-in bogie prepared
- Roll-in bogie equipped
- Variable speed incline apron feeder
- Chute arrangements offering blending between decks
- Incline Apron feeder
- Light duty belt feeder



**H6203**

Weight (Est)	46,700kg (102,955lbs)
Transport width	3.2m (10'6")
Transport length	19.6m (64'3")
Transport height	3.6m (11'10")
Working width	16.25m (53' 3")
Working length	18.85m (61'10")
Working height	4.8m (15'9")

\*Output potential depends on application  
Engines are available that are certified to US EPA and EU off road diesel emission standards. Talk to your dealer about possible certification options (i.e. Tier 3/Stage 3A, Tier 4/Stage 3B, Tier 4F/Stage 4).

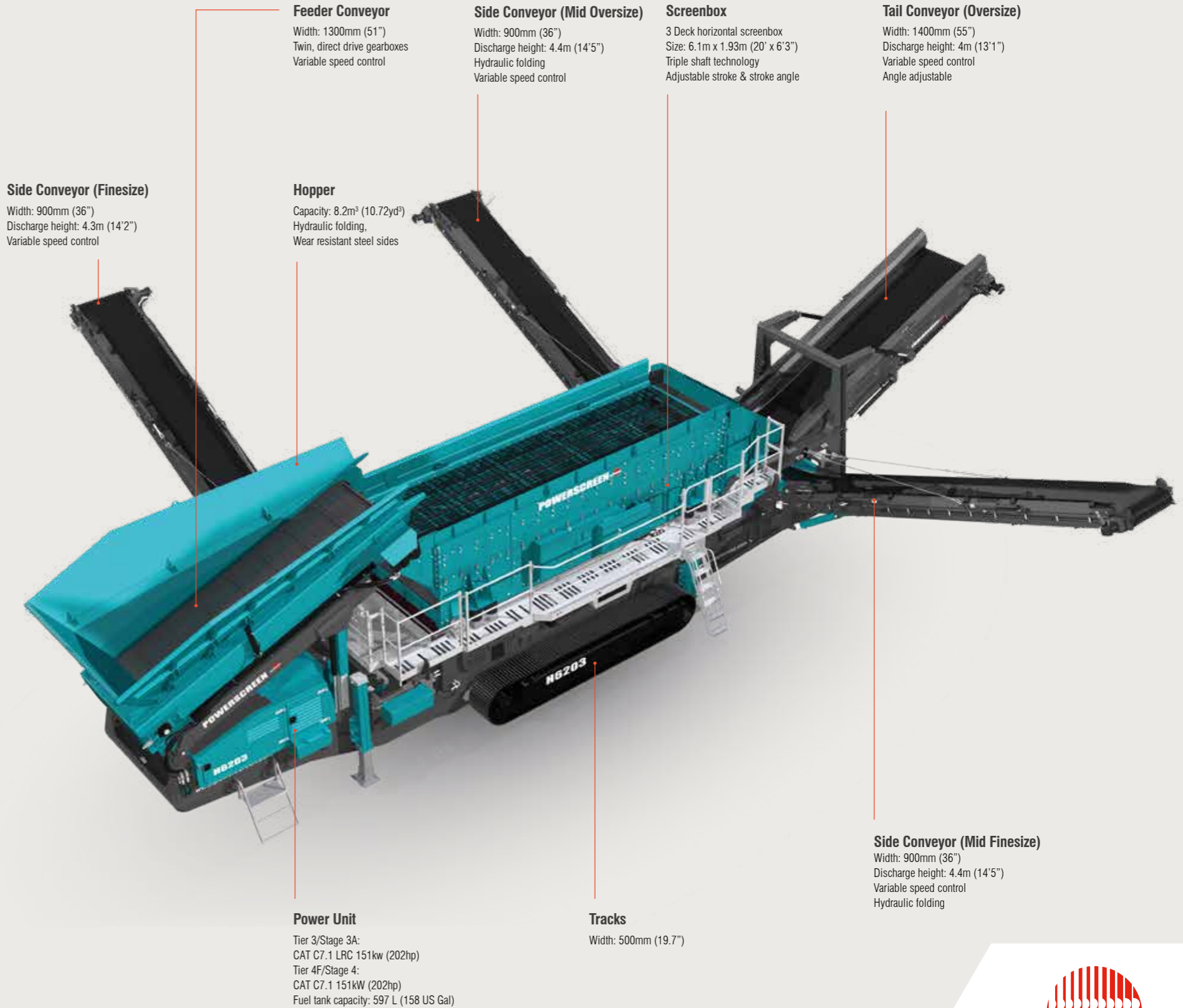

# H6203R

The Powerscreen® H range features horizontal screens ideal for handling high volumes of sticky materials and for the exact, fine sizing demanded in many construction contracts. The H6203R offers high capacity output of up to 800tph / (882 US tph).

The adjustable elliptical throw combines linear and circular amplitude producing an aggressive screening action. Powerscreen® H products are especially effective for scalping after a primary impact or jaw crusher and really have outstanding performance when screening out specific small sizes. Ideally suited to applications such as natural and crushed aggregate, coal, iron ore, recycled concrete and asphalt.

**Features & Benefits**

- High capacity variable speed belt feeder
- Oil bath screenbox bearing lubrication
- Screen walkway and access ladder
- Hydraulic folding stockpiling conveyors
- Engine protection shutdown system
- Heavy duty triple shaft screenboxes with adjustable stroke, angle and speed
- Elliptical throw adjustable up to 19mm (3/4")
- Diesel hydraulic power unit
- Heavy duty, low ground pressure tracks
- Direct feed hopper with impact bars and rollers
- Mid-over's product tail conveyor
- Oversize product side conveyor
- Full walkway access on three sides of screen
- Hydraulic load sensing on screen collection & fines discharge conveyors

**Options**

- Radio controlled tracking
- Dual Power (additional electric hydraulic drive)
- Roll-in bogie prepared
- Roll-in bogie equipped
- Variable speed incline apron feeder
- Auto lubrication system
- Wear resistant or mild steel punch plate screens
- Hinged trap doors offering blending options between decks



**H6203R**

Weight (Est)	45,000kg (99,208lbs)
Transport width	3.2m (10'6")
Transport length	18.99m (62'4")
Transport height	3.6m (11'10")
Working width	16.27m (53'4")
Working length	21.3m (69' 11")
Working height	4.7m (15' 5")

\*Output potential depends on application  
Engines are available that are certified to US EPA and EU off road diesel emission standards. Talk to your dealer about possible certification options (i.e. Tier 3/Stage 3A, Tier 4/Stage 3B, Tier 4F/Stage 4).

